



2017 - 2018 Ford F350 Super Duty Dually

Relearn: Triggering tool required.¹



NEW

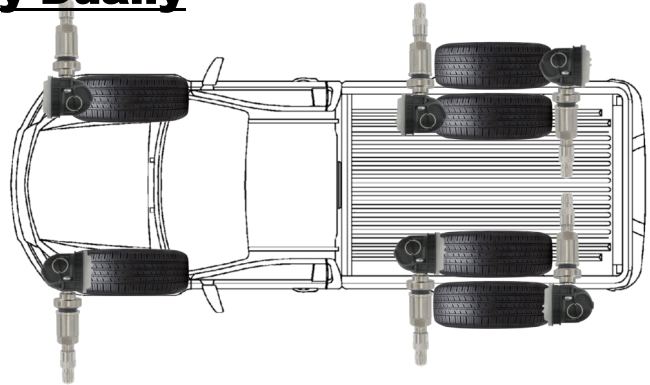

**All Sensors: 9291
Valve: VS-241**

¹Perform relearn before installing the outer rear wheels on the vehicle.

2014 - 2018 RAM 3500 Dually with Outer Alloy

Relearn: Drive for 15mins.

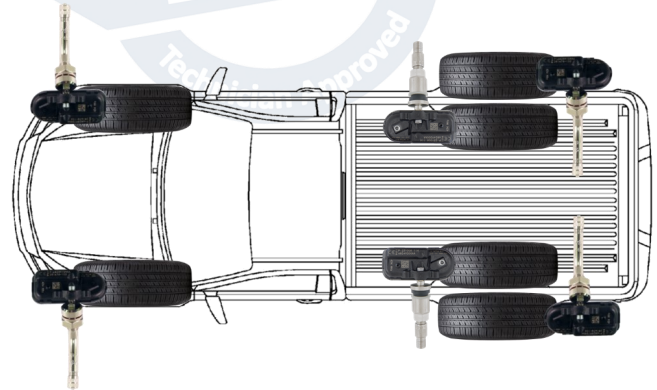

**Outer Sensor: 6829
Inner Sensor: 6825²
Outer Valve: VS-35
Inner Valve: VS-241³**

2014 - 2018 RAM 3500 Dually with Outer Steel

Relearn: Drive for 15mins.

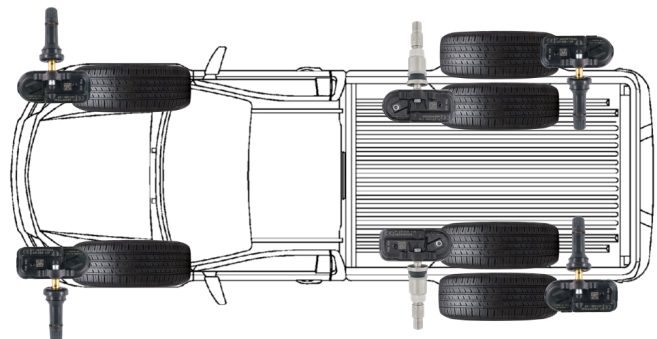

**Outer Sensor: 6815
Inner Sensor: 6825²
Outer Valve: VS-65
Inner Valve: VS-241³**

²6825 sends a different signal to inform the ECU that it is an inner wheel sensor. An inner sensor cannot be installed in an outer wheel.

³Original valve is VS-65 but DILL recommends corrosion-resistant VS-241 which includes a dual-seal cap to aid in the monthly pressure checks.